

5 Port Mechanical Valve/Metal Seal

Series **VFM200**

**Compact design,
Large flow capacity/Cv.1.0**

**High cycle rate,
Long life/300c.p.m.**

Piping possible to any EXH port.

Proper countermeasures can be taken for applications in which the noise of the exhaust could cause problems to the surroundings.

External pilot model available. (Option)

Foot bracket and manifold mounting possible.



Specifications

Fluid	Air, Inert gas
Operating pressure	0.1 to 1.0MPa ⁽¹⁾
Ambient and fluid temperature	-5 to 60°C (No freezing)
Effective area (Cv)	18mm ² (1.0)
Maximum frequency (Mechanical operation style)	300 c.p.m or less
Lubrication	Not required/Turbine oil #1 (ISO VG32)
Port size (Nominal size)	Main valve Rc(PT) 1/4 (8A)
	Pilot valve (EXH)/M5 X 0.8
Option	Foot bracket ⁽²⁾
Weight (Basic)	300g



* Contact SMC for manifold mounting style.

Note 1) External pilot style Main valve: 0 to 1.0MPa
Pilot valve: 0.1 to 1.0MPa

Note 2) The standard body can not be retrofitted with a foot bracket.

Model

	Actuator	Model	Actuator part No.	Application
Mechanical operation	Basic	VFM250-02-00	—	—
	Roller lever	VFM250-02-01	VM-01C	Polyacetal roller
		VFM250-02-01S	VM-01CS	Hard steel roller
	One way roller lever	VFM250-02-02	VM-02C	Polyacetal roller
		VFM250-02-02S	VM-02CS	Hard steel roller
	Straight plunger	VFM250-02-05	VM-05D	—
	Roller plunger	VFM250-02-06	VM-06D	Polyacetal roller
		VFM250-02-06S	VM-06DS	Hard steel roller
Toggle lever	VFM250-02-08	VM-08D	—	
Manual operation	Push button (Mushroom)	VFM250-02-30R	VM-30CR	Red
		VFM250-02-30B	VM-30CB	Black
		VFM250-02-30G	VM-30CG	Green
		VFM250-02-30Y	VM-30CY	Yellow
	Push button (Extended)	VFM250-02-32R	VM-32CR	Red
		VFM250-02-32B	VM-32CB	Black
		VFM250-02-32G	VM-32CG	Green
		VFM250-02-32Y	VM-32CY	Yellow
	Push button (Flush)	VFM250-02-33	VM-33C	With a set of red, black, green, yellow
		VFM250-02-34R	VM-34CR	Red
	Twist selector (2 position)	VFM250-02-34B	VM-34CB	Black
		VFM250-02-34G	VM-34CG	Green
		VFM250-02-34Y	VM-34CY	Yellow
	Key selector (2 position)	VFM250-02-36	VM-36C	—



Note) Actuator replacement is available for all styles.

How to Order

VFM25 0 02 01 S

Body option		Port size		Actuator		Suffix of actuator		Option	
0	Internal pilot style	02	Rc(PT) 1/4	00	Basic	S	Hard steel roller	F	Foot bracket (Only internal pilot)
1	External pilot style			01	Roller lever	R	Red		
				02	One way roller lever	B	Black		
				05	Straight plunger	G	Green		
				06	Roller plunger	Y	Yellow		
				08	Toggle lever				
				30	Push button (Mushroom)				
				32	Push button (Extended)				
				33	Push button (Flush)				
				34	Twist selector (2 position)				
				36	Key selector (2 position)				

S□A

V□A

S□A

V□A

Construction

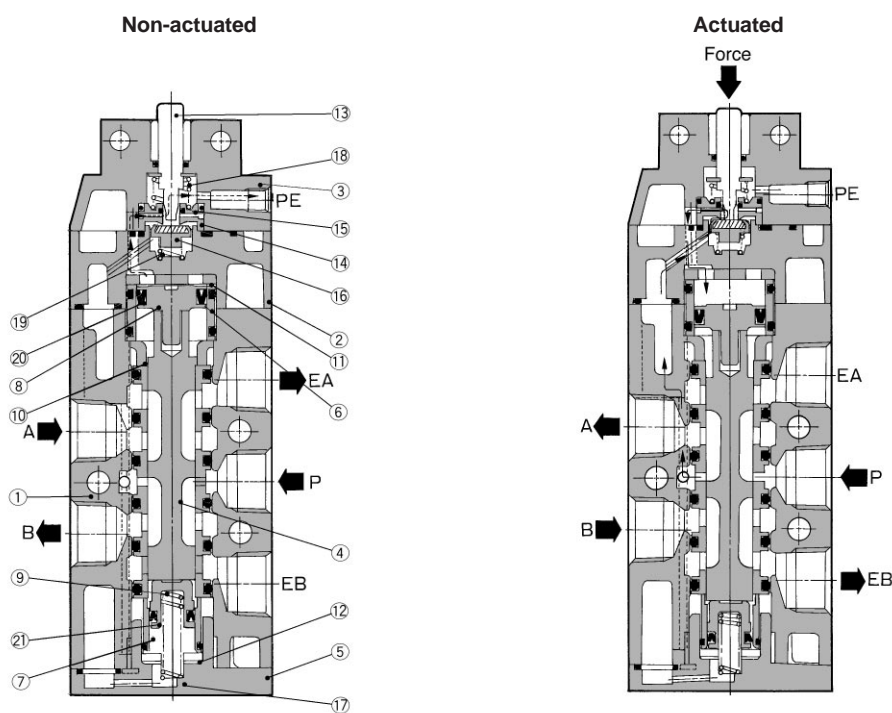

VM/VR

VH

Component Parts

No.	Description	Material	Notes
①	Body	Aluminum alloy	Metallic plated
②	Pilot body	Zinc alloy	Metallic plated
③	Head cover	Zinc alloy	Black zinc chromate
④	Spool/sleeve	Stainless steel	
⑤	End cover	Polyacetal	
⑥	Piston guide	Brass	
⑦	Piston guide for end cover	Brass	
⑧	Piston	Polyacetal	
⑨	Piston for end cover	Polyacetal	
⑩	Guide bushing	Polyacetal	
⑪	Cushion	Urethane rubber	

No.	Description	Material	Notes
⑫	Cushion for end cover	Urethane rubber	
⑬	Plunger	Stainless steel	
⑭	Valve seat (A)	Brass	
⑮	Valve seat (B)	Brass	
⑯	Valve	NBR, Brass	
⑰	Return spring	Stainless steel	
⑱	Return spring	Stainless steel	
⑲	Valve spring	Stainless steel	
⑳	Mini Y packing	NBR	
㉑	Mini Y packing	NBR	

VFM200

Series VFM200

Basic/VFM250-02-00

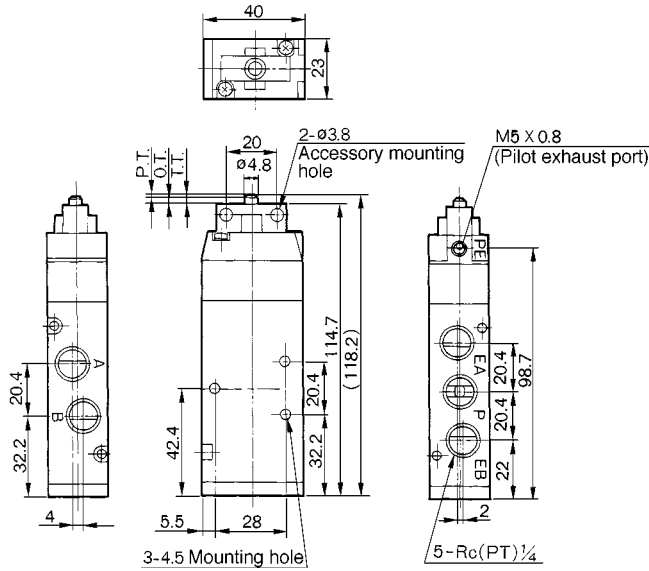

JIS Symbol

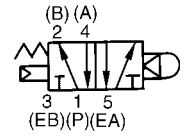

* 0.5MPa supply

F.O.F.*	16N
P.T.	1mm
O.T.	2mm
T.T.	3mm

Roller Lever/VFM250-02-01, VFM250-02-01S

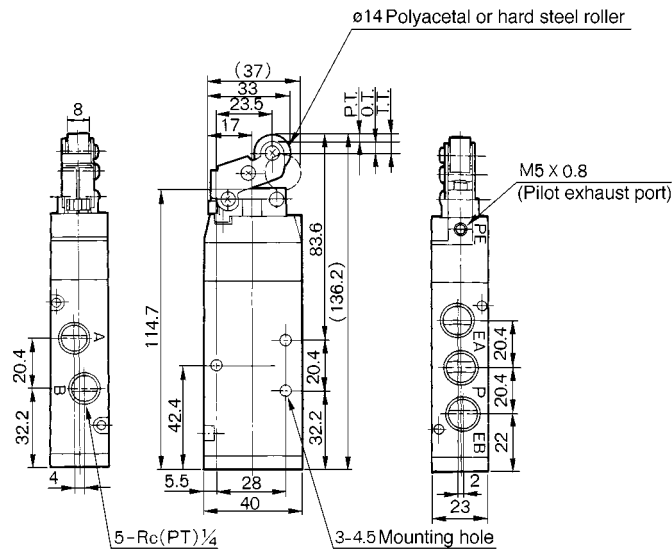

JIS Symbol

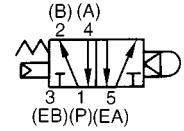

* 0.5MPa supply

F.O.F.*	8N
P.T.	2.2mm
O.T.	4mm
T.T.	6.2mm

One Way Roller Lever/VFM250-02-02, VFM250-02-02S

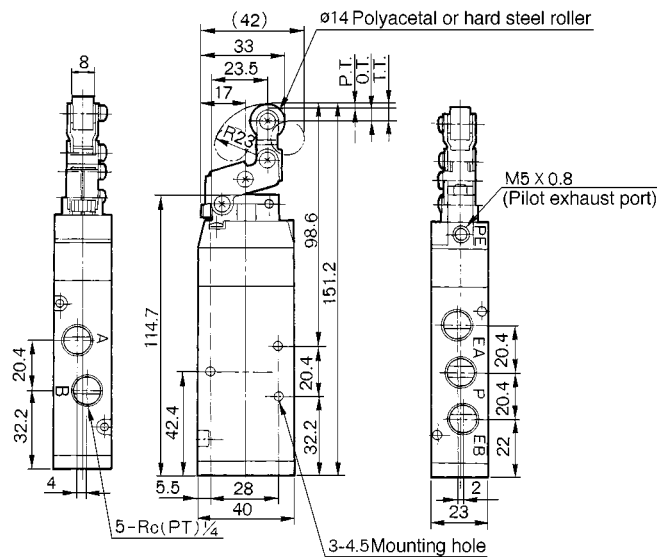

JIS Symbol

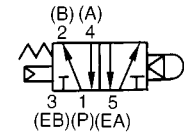

* 0.5MPa supply

F.O.F.*	7N
P.T.	2.4mm
O.T.	4.6mm
T.T.	7mm

Series VFM200

Straight Plunger/VFM250-02-05

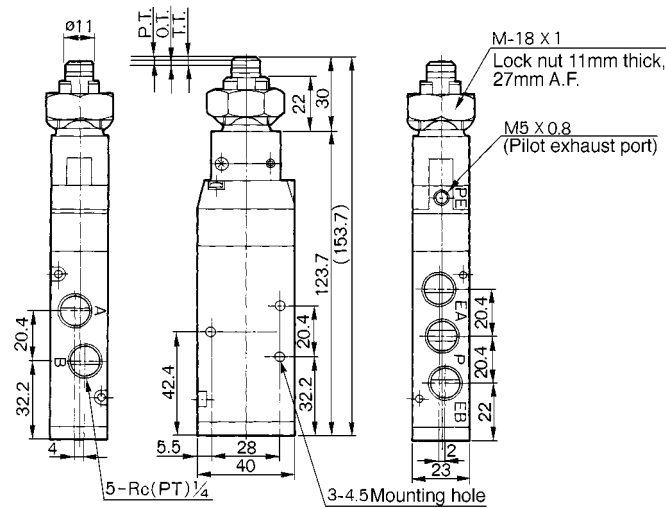

Panel mounted hole

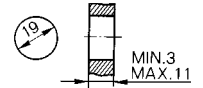

JIS Symbol

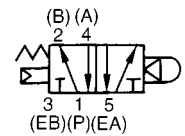

* 0.5MPa supply

F.O.F.*	20N
P.T.	1.5mm
O.T.	2mm
T.T.	3.5mm

S□A

V□A

S□A

V□A

VM/VR

VH

Roller Plunger/VFM250-02-06, VFM250-02-06S

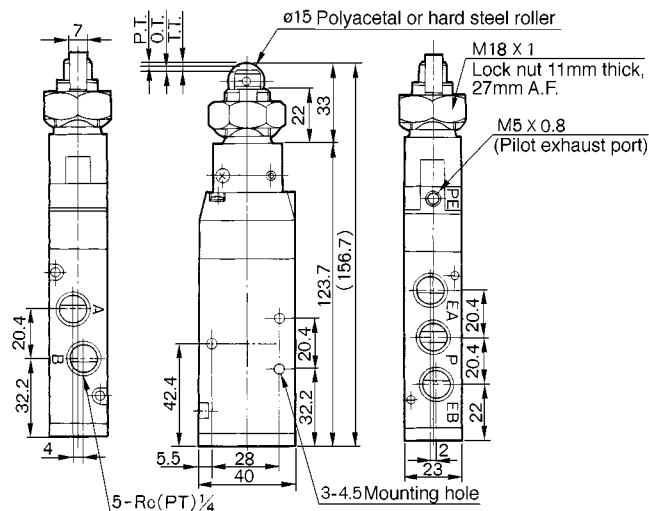

Panel mounted hole

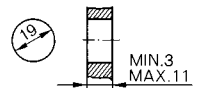

JIS Symbol

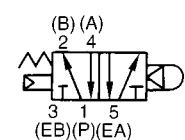

* 0.5MPa supply

F.O.F.*	20N
P.T.	1.5mm
O.T.	2mm
T.T.	3.5mm

Toggle Lever/VFM250-02-08

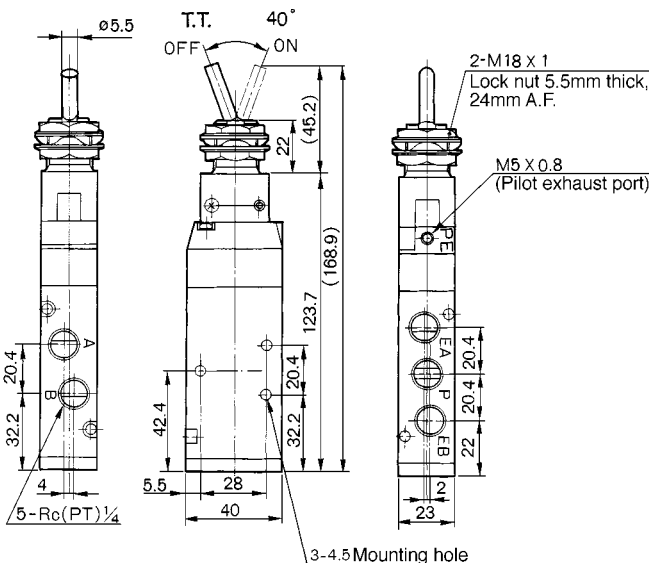

Panel mounted hole

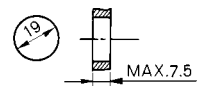

JIS Symbol

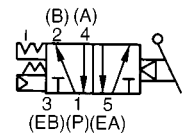

* 0.5MPa supply

F.O.F.*	15N
T.T.	40°

VFM200

Series VFM200

Push Button (Mushroom)/VFM250-02-30R, B, G, Y

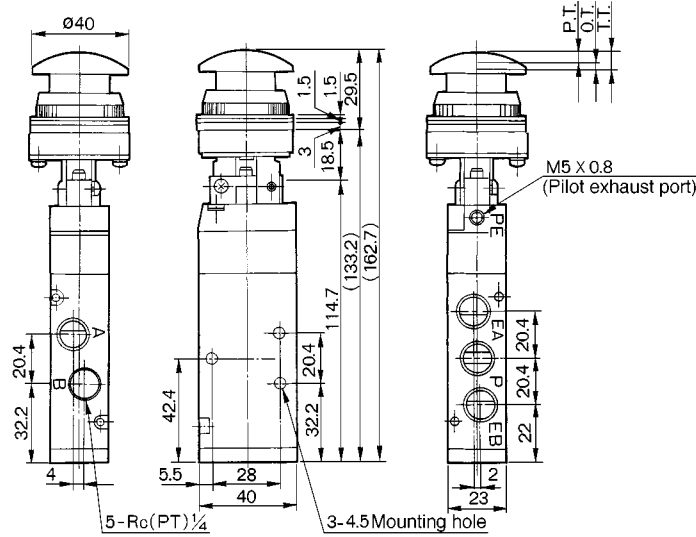

Panel mounted hole

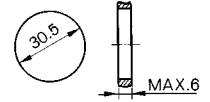

JIS Symbol

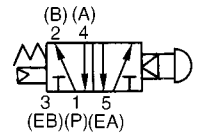

* 0.5MPa supply

F.O.F.*	21N
P.T.	4.8mm
O.T.	1.7mm
T.T.	6.5mm

Push Button (Extended)/VFM250-02-32R, B, G, Y

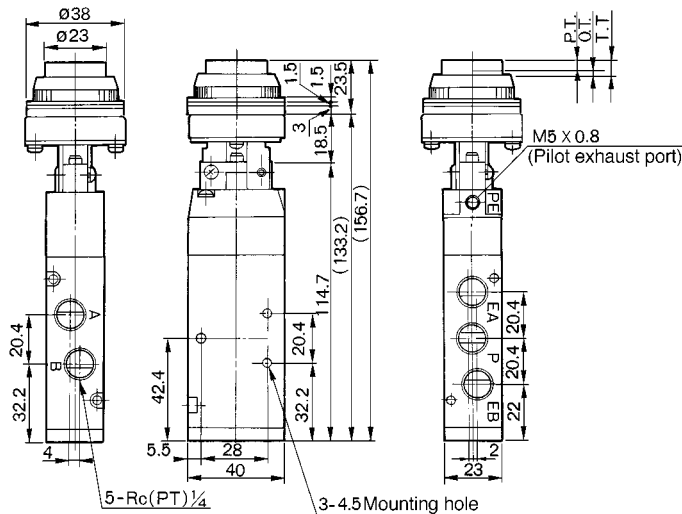

Panel mounted hole

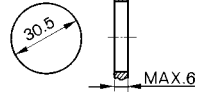

JIS Symbol

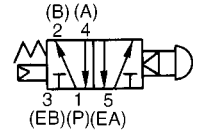

* 0.5MPa supply

F.O.F.*	21N
P.T.	4.8mm
O.T.	1.7mm
T.T.	6.5mm

Push Button (Flush)/VFM250-02-33

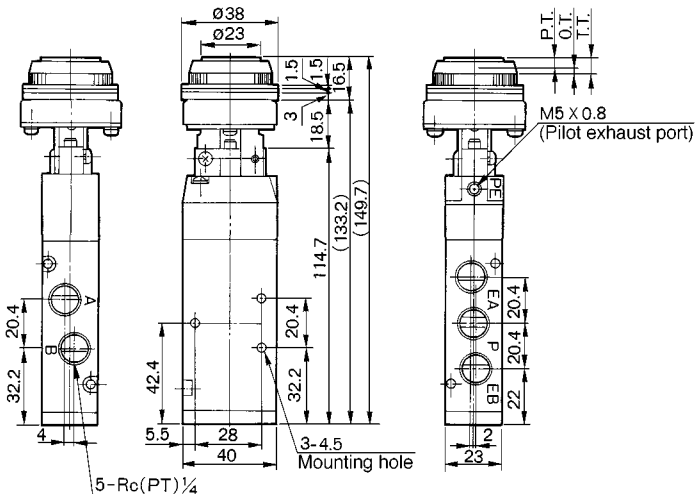
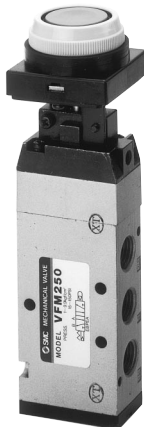

Panel mounted hole

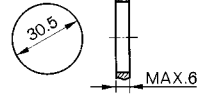

JIS Symbol

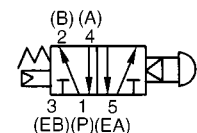

* 0.5MPa supply

F.O.F.*	21N
P.T.	4.8mm
O.T.	1.7mm
T.T.	6.5mm

Series VFM200

Twist Selector (2 position)/ VFM250-02-34R, B, G, Y

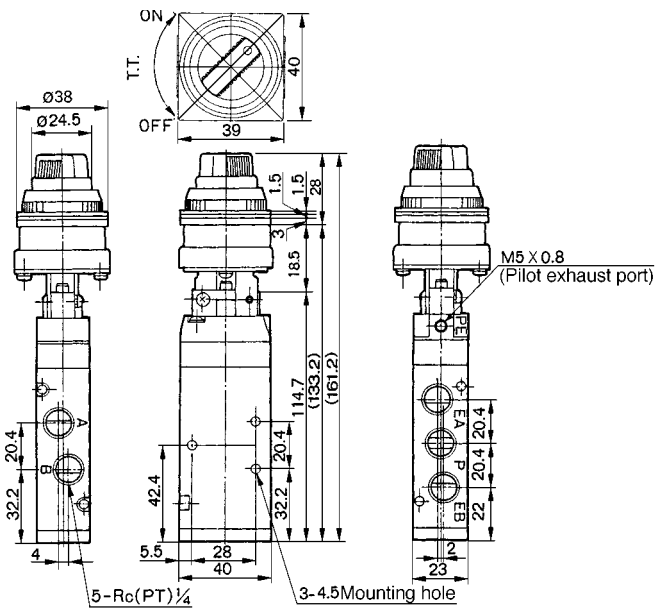

Panel mounted hole

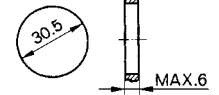

JIS Symbol

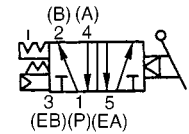

* 0.5MPa supply

F.O.F.*	23N
T.T.	90°

S□A

V□A

S□A

V□A

VM/VR

VH

Key Selector (2 position)/VFM250-02-36

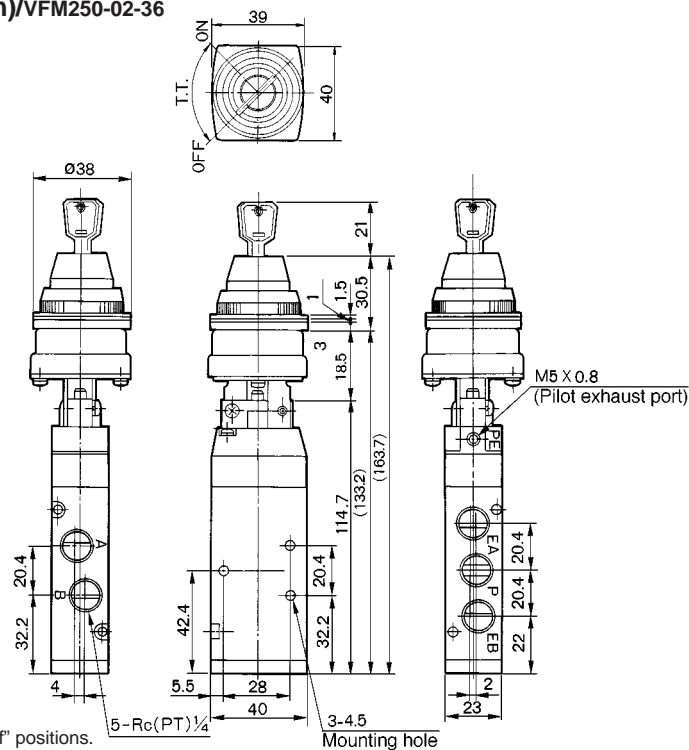
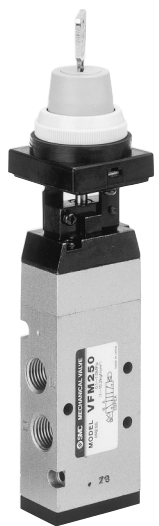

Panel mounted hole

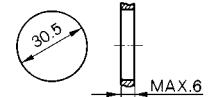

JIS Symbol

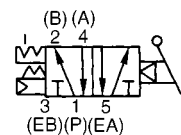

* 0.5MPa supply

F.O.F.*	26N
T.T.	90°

Key can be removed in "on" and "off" positions.

External Pilot Style VFM251 Type

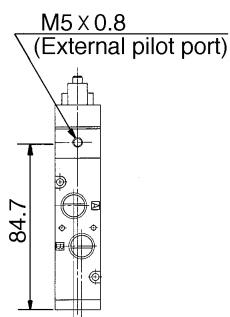

With Foot Bracket VFM250-02-□□-F

